

The ChemFlex name represents a flexible and highly configurable chemical dispense platform that offers high performance and reliability. Each unit is configured based on the needs of the intended application.



## Product Overview

The ChemFlex platform offers significant configurability in the areas of dispense technology, redundancy, capacity and component selection. This flexibility enables every unit to be configured in the most cost-effective way for a specific application. Different configurations share the same basic components, controls architecture and maintenance models for ease of operation and spares optimization.

## Features and Benefits

- Highly configurable product platform
  - Options for 1, 2 or 3 engines
  - Diaphragm or centrifugal pumps
- Reliable performance for high-volume manufacturing settings
  - Design and component selection based on 25+ years of chemical experience
- Single platform for chemical and slurry
  - Common components, S/W, training, spares and operation
- Built in a center of manufacturing excellence
  - ISO9001 certified
  - Formal QA/QC procedures, documentation standards, and final test procedures

## Performance and Reliability

- Uptime >99.98% (redundant configuration)
- MTBF >8000 hours
- MTTR <2 hours

## Configuration Options

- Dispense Options
  - Air-operated pumps (A)
  - Centrifugal pumps (C)
- Flow Ranges
  - <10 LPM (A)
  - 10-20 LPM (A, C)
  - 20-40 LPM (A, C)
  - 40-80 LPM (C)
- Engine (Pump Circuit) Configurations
  - Each unit can have 1, 2 or 3 engines
  - Each engine can have 1-6 filters
  - Options for 2 pumps per engine
  - Units with >1 engine can perform concurrent operations (e.g. transfer & dispense)
- Source Configurations
  - Pressurized or atmospheric chemical source (drums/totes)
  - Valves for 2 source containers standard with option for 4 source containers
- Filtration Options
  - 10" or 20" filter cartridges
  - No filtration, single-pass or stabilized filtration
  - Drum/tank polish available with >1 engine
- Tank and Outlet Options
  - 0, 1, or 2 daytanks
  - One outlet valve standard with option for up to 3 outlets
  - Dead-head distribution or fab-wide recirculation

## Example Flow Paths

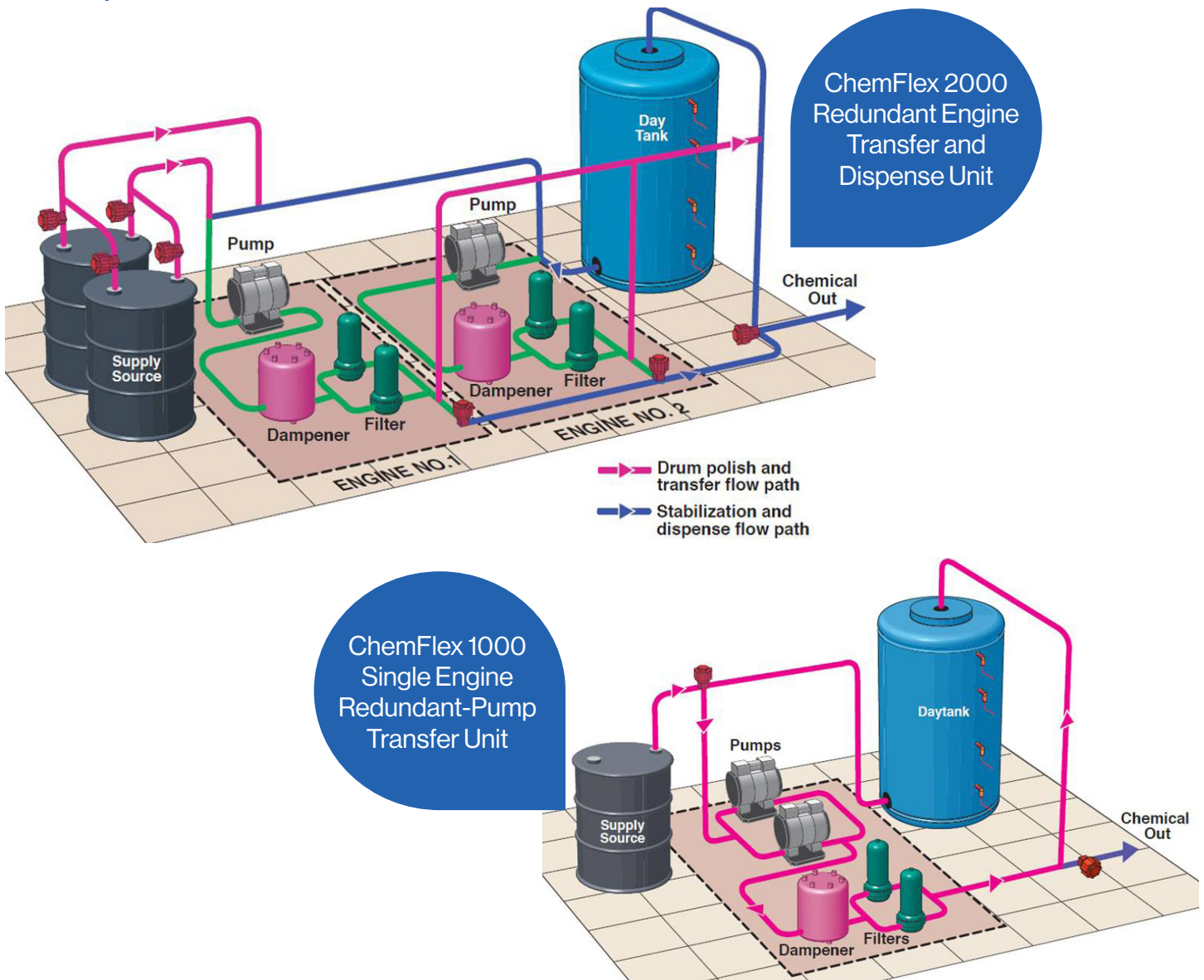

## Safety Features

- Segregated cabinet compartments with 110% volume containment
- Dual-level cabinet leak detection
- Door interlocks
- DIW or N<sub>2</sub> spray-guns
- CDA or N<sub>2</sub>-purged electrical compartment
- Audible and visual warnings and alarms
- Local and remote EMO
- Transparent door panels for viewing and troubleshooting
- Options for exhaust sensor type, high-flow sensor and other instrumentation
- Designed for compliance with SEMI S2, S8 and S14 guidelines, and CE low-voltage, Machinery and EMC directives
- Optional UV/IR fire detection and CO<sub>2</sub> fire suppression for solvent systems

## Typical Utility Requirements

Utility	Connection Type	Flow/Pressure
Electrical	N/A	24 VDC, 7A (with air-operated pump)
UPW Supply	½" Flaretek	40-60 psi
UPW Return	½" Flaretek	<25 psi
CDA	½" SST compression	100-125 psi
Process N <sub>2</sub>	½" SST compression	100-125 psi
Exhaust	6" connection	200 SCFM typical, 0.5" WC

## Cabinet Layouts & Dimensions

Cabinet Type	W x D x H in Inches (mm)
ChemFlex 1000	60" x 30" x 86" (1524 x 762 x 2185)
ChemFlex 2000	95" x 30" x 86" (2413 x 762 x 2185)
ChemFlex 3000	112" x 30" x 86" (2845 x 762 x 2185)

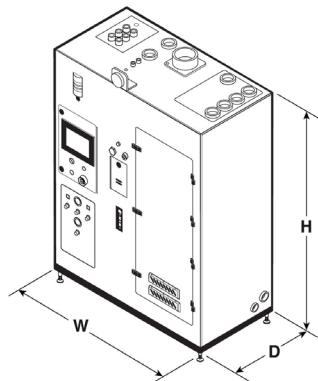

ChemFlex 1000

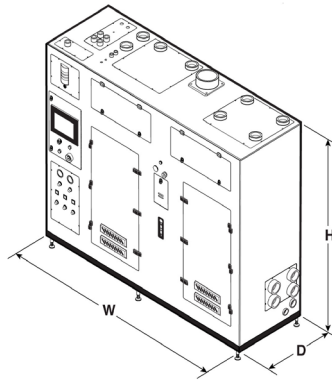

ChemFlex 2000

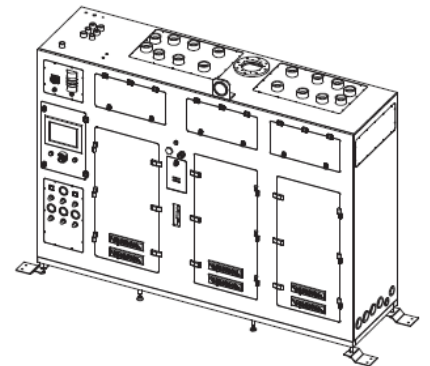

ChemFlex 3000

### Contact Us

Air Liquide Electronics  
 Advanced Equipment Systems Division (AES)  
 Phone: 952-937-6340  
[ww-sales-equipment@airliquide.com](mailto:ww-sales-equipment@airliquide.com)



The world leader in gases, technologies and services for Industry and Health, Air Liquide is present in 80 countries with approximately 68,000 employees and serves more than 3 million customers and patients.