



ChemPrep™ Inline Chemical Blend System

The ChemPrep Inline blend system utilizes Air Liquide's patented inline blend technology with proprietary mixing and real-time metrology feedback control to produce high-accuracy and high-capacity blends.



Product Overview

The ChemPrep Inline is an extremely flexible, high-capacity inline blending system. The flexibility makes it suitable for anything from simple dilutions to high-accuracy developer blends to more complex blends such as BOE or multiple-recipe configurations.

Inline metrology provides real-time feedback enabling the system to actively adjust the chemical concentration to meet the process specifications.

Features and Benefits

- Flexible process support
 - Suitable for simple dilutions, such as HF, and NH_4OH , or 2, 3 and 4 constituent blends
 - Produce multiple recipes from a single unit
- Reduced Cost of Ownership
 - Cost savings available as compared with purchasing pre-diluted chemicals
- High-accuracy blending
 - Patented technology with proprietary mixing and metrology feedback control
- Built in a center of manufacturing excellence
 - ISO9001 certified
 - Formal QA/QC procedures, documentation standards, and final test procedures

Performance and Reliability

- Typical Blend Capacity: 10-40 LPM
- Blend Accuracy: Up to 0.1% relative error
- Uptime >99.95%

Theory of Operations

The ChemPrep Inline blender uses precision metering and real-time metrology feedback control to produce high-accuracy blends. Each constituent is controlled by a dedicated flow controller and the flow controllers send real-time data to the PLC for comparison with the target blend ratio.

A static mixer ensures a homogenous blend after which the blended chemical is measured by dual metrology probes. The combination of flow rate monitoring and PID loop control based on the inline concentration measurement enables the ChemPrep Inline to produce extremely accurate chemical blends. Out-of-specification chemical is diverted to drain until the concentration is brought back within the specification. In-spec chemical fills the appropriate tank based on signals from the level sensors.

Configuration Options

- Multiple recipe configurations
 - Blends with up to 4 constituents
 - Produce multiple unique blends from one system
- Metrology
 - Dual conductivity standard
 - Option for multiple measurement points for 3 and 4 constituent blends
- Drum or pressurized chemical supply
- Tank management
 - Single-tank standard with option for dual tanks
 - Option for tank circulation/transfer pump
 - Option for tank monitoring metrology

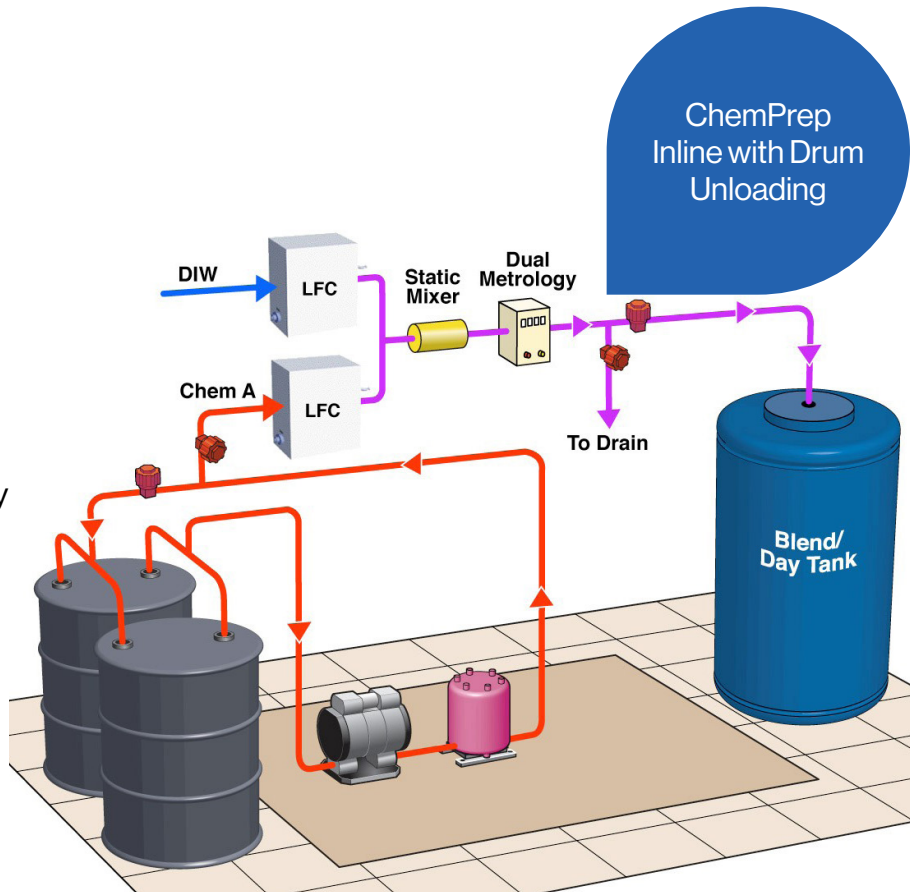

ChemPrep Inline with Dual-Recipe Capability

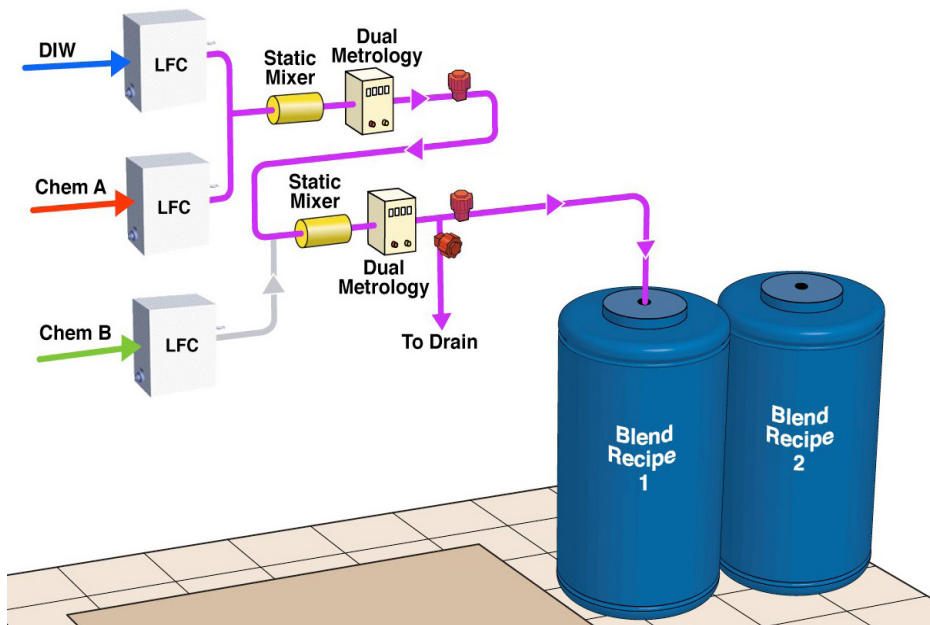

Safety Features

- Segregated cabinet compartments with 110% volume containment
- Dual-level cabinet leak detection
- Door interlocks
- DIW spray-guns
- CDA-purged electrical compartment
- Audible and visual warnings and alarms
- Local and remote EMO
- Transparent door panels for viewing and troubleshooting
- Configurable alarms for blending performance
- Designed for compliance with SEMI S2, S8 and S14 guidelines, and CE low-voltage, Machinery and EMC directives

Typical Utility Requirements

Utility	Connection Type	Flow/Pressure
Electrical	N/A	Configuration-specific
UPW Supply	¾" Flaretek	40-60 psi
UPW Return	½" Flaretek	<25 psi
CDA	½" SST compression	100-125 psi
Process N ₂	½" SST compression	100-125 psi
Exhaust	6" connection	200 SCFM typical, 0.5" WC

Cabinet Layouts & Dimensions

Cabinet Type	Description	W x D x H in Inches (mm)
ChemPrep 1000 Inline	Single-bay cabinet	60" x 30" x 86" (1524 x 762 x 2185)
ChemPrep 2000 Inline	Two-bay cabinet	95" x 30" x 86" (2413 x 762 x 2185)

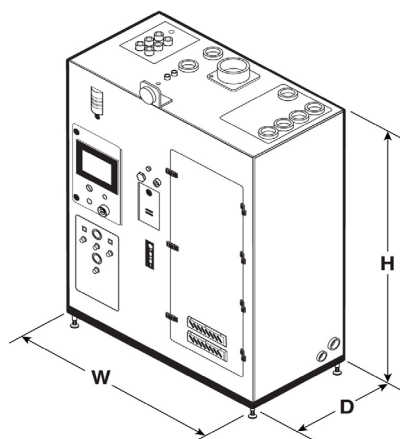

ChemPrep 1000 Inline

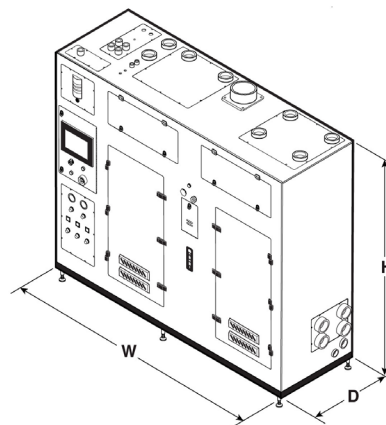

ChemPrep 2000 Inline

Contact Us

Air Liquide Electronics
 Advanced Equipment Systems Division (AES)
 Phone: 952-937-6340
ww-sales-equipment@airliquide.com



The world leader in gases, technologies and services for Industry and Health, Air Liquide is present in 80 countries with approximately 68,000 employees and serves more than 3 million customers and patients.